



COLORED DIAMOND IDENTIFICATION AND ORIGIN REPORT

GIA REPORT 1122308250

July 09, 2010

Shape and Cutting Style **Heart Modified Brilliant**

Measurements **5.67 x 6.04 x 2.64 mm**

Weight **0.63 carat**

Color Grade

Origin **NATURAL**

Grade **FANCY DEEP**

..... **BROWN-PINK**

Distribution **EVEN**

Comments:

None

GIA
COLORED
DIAMOND
SCALE

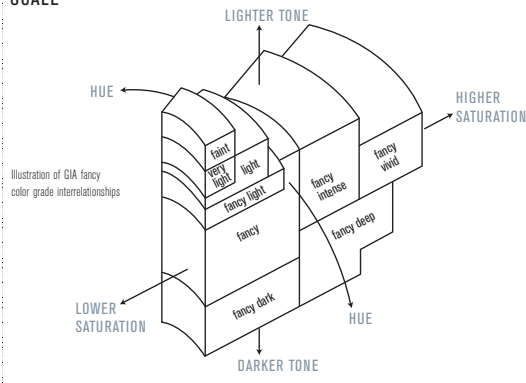

210506776631

This is an electronic version of a GIA Report. This Report is not a guarantee, valuation or appraisal and contains only the characteristics of the diamond described herein after it has been graded, tested, examined and analyzed by the laboratory providing this Report ("GIA") and/or has been inscribed using the techniques and equipment used by GIA at the time of the examination and/or inscription. Inscriptions reported in this document are not a guarantee, validation, or warranty of a diamond's quality, country of origin or source; or that the diamond will be identifiable by the inscription in the future (since inscriptions can be removed). GIA makes no representation concerning any trademark, word, or symbol which is inscribed by GIA or which is identified on this Report. The recipient of this Report may wish to consult a credentialed jeweler or gemologist about the information contained herein.

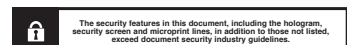

IMPORTANT LIMITATIONS ON PAGE 2

© 2008 GEMOLOGICAL INSTITUTE OF AMERICA, INC.

IMPORTANT LIMITATIONS

This is an electronic version of a GIA Report. This Report is not a guarantee, valuation or appraisal, and the laboratory providing this Report ("GIA") has made no representation or warranty regarding this Report, the diamond described herein or any inscription thereon. This Report contains only the characteristics of the diamond described herein after it has been graded, tested, examined, and analyzed (collectively, "examination" or "examined") and/or inscribed, using the techniques and equipment used by GIA at the time of the examination and/or inscription. The results of any other examination performed on the diamond may differ depending upon (i) when, how and by whom the diamond is examined and (ii) the changes and improvements in techniques and equipment that may have occurred which may enable an examiner to detect, among other things, the use of processes for altering the characteristics of a diamond which use was previously undetectable by GIA, or alterations which became reversible, even if the process remains undetectable. The trademark, service mark, logo, words, characters or other symbols of an inscription, other than a GIA Report number, or a GIA trademark, service mark or logo, are solely determined by and attributable to the Client for whom this Report was prepared and are neither attributable to nor to be understood as an indication of any determination by GIA.

The recipient agrees and acknowledges that GIA has provided this Report and any inscription for a relatively small fee compared to the present and potential value of the diamond described herein only because this Report and any inscription are subject to the following limitations on the liability of GIA and the limitations described in the agreements pursuant to which this Report and any inscription are made, all of which extend to the Client for whom this Report and any inscription were prepared and to every other person to whom this Report or the inscribed diamond is distributed or shown:

(1) TO THE EXTENT PERMITTED BY APPLICABLE LAW, GIA AND ITS DIRECTORS, EMPLOYEES AND AGENTS SHALL NOT BE LIABLE FOR ANY LOSS, DAMAGE OR EXPENSE RESULTING FROM ANY ERROR IN OR OMISSION FROM THIS REPORT OR FROM THE ISSUANCE OF OR USE OF THIS REPORT OR ANY INSCRIPTION, EVEN IF THE LOSS, DAMAGE OR EXPENSE WAS CAUSED BY GIA OR ANY OF ITS DIRECTORS, EMPLOYEES OR AGENTS AND (2) IN ANY EVENT, GIA AND ITS DIRECTORS, EMPLOYEES AND AGENTS SHALL NOT BE LIABLE FOR ANY SPECIAL, INDIRECT, INCIDENTAL, EXEMPLARY, PUNITIVE, STATUTORY, OR CONSEQUENTIAL DAMAGES, INCLUDING LOST PROFITS, RESULTING FROM ANY ERROR IN OR OMISSION FROM, OR FOR THE ISSUANCE OF OR USE OF, THIS REPORT OR ANY INSCRIPTION, OR FOR ANY ERROR IN OR OMISSION FROM THIS REPORT OR ANY INSCRIPTION CAUSED BY THE ACTS OF OTHERS, EVEN IF ADVISED OF THE POSSIBILITY OF SUCH DAMAGES.

As a protection to the public and GIA, this Report, the name, trademarks, service marks and logos of GIA and Gemological Institute of America, Inc., or any part of any inscription which relates to a GIA Report number or to a GIA or Gemological Institute of America, Inc. trademark, service mark, or logo, may not be used in whole or in part for purposes of advertising, publicity or promotion, and this Report may not be referred to as a guarantee, valuation or an appraisal.